

PJ-201 Series Print Circuit Preform Jumpers

Print Circuit Preform Jumpers



Specifications

Materials:

Contact Material: .020" diameter 70/30 Brass Wire

Finish: .0001" Matte Tin over .00005 Nickel

Mechanical:

Mounting Holes: Two .040" diameter +/- .003" plated through holes

Electrical:

Maximum Current: 2 amperes

PJ-201 Contacts

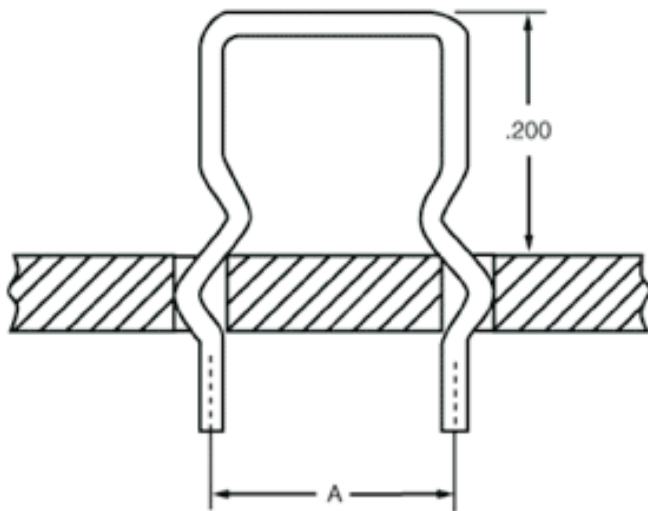

PJ-201 Dimensions

<u>Part Number</u>	<u>Dimension A</u>
PJ-201-10-T	.100
PJ-201-20-T	.200
PJ-201-25-T	.250
PJ-201-30-T	.300

Ordering Information

Example:

PJ-201 - 30 - T

● **Series Designation:**
PJ-201

● **Lead Spacing:**
10 = .100"
20 = .200"
25 = .250"
30 = .300"

● **Finish:**
Matte Tin over Nickel

Product Description

The PJ-201 series is the low cost alternative for the circuit designer's printed circuit mounted, jumper requirements. Numerous standard offerings in spacing dimensions eliminate time consuming and costly fabrication of jumpers by production personnel. The preset, "above board" positioning of this series guarantees adequate clearance across circuit board paths and precludes the need for expensive teflon insulation in many applications.

The exclusive detented leg design insures positive positioning and retention of the PJ-201 series during wave soldering operations. Due to its spring brass construction, this jumper will provide a rugged installation, resistant to damage and possible short circuits.

As well as serving a jumper function, the PJ-201 can provide a simple, reliable and economical means for the "hard wire" programming of circuit board logic. Operations of multi-function, logic card modules may be permanently dedicated through the cutting of appropriate PJ-201 jumpers on the board.

Certificate of Compliance with Directive 2002/95/EC RoHS and REACH Regulations EC 1907/2006

This is to certify that Components Corporation designs, manufactures and supplies products to our customers that are in compliance with RoHS Directive 2002/95/EC and REACH Regulations EC 1907/2006. This also pertains to procurement of raw material, component parts and processes.