

TP-107 Series Surface Mount Tape and Reel Test Points

Surface Mount, Tape & Reel Test Points



Specifications

Materials:

Contact Material: .015" x .040" Phosphor Bronze #510 Alloy, 1/2 hard

Finish: .0001 Matte Tin over .00001 Nickel

Tape Material: 12mm Wide;

Pitch: 4mm;

Conductive polycarbonate carrier meets ANSI/EIA-481 Standard

Reel Size: TP-107-02-1-T = 7" diameter: 1000 pieces per reel

TP-107-02-5-7 = 13" diameter: 5000 pieces per reel

Pad Size: .185" x .135"

U.S. Patent #5,747,740

TP-107 Contacts

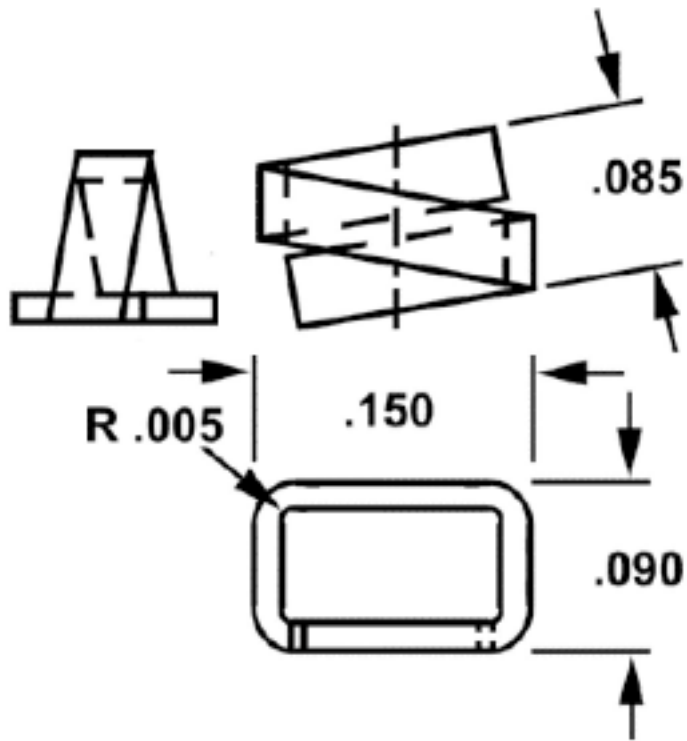

Ordering Information

Example:

TP-107 - 02 - 1 - T

● **Series Designation:**
TP-107

● **Packaging:**
01 = Bulk Packaging
02 = Tape & Reel

● **Quantity Per Reel:**
1 = 1,000 pieces
5 = 5,000 pieces

● **Finish:**
Matte Tin over Nickel

Product Description

How the fabricators of SMT printed wiring boards may take advantage of the convenience of field testing with the unique loop design of Components Corporation's TP-107 series of surface mounted, printed circuit test points. The profile of the TP-107 readily accepts most commercially available spring clips and probes while providing a positive and secure anchor to the SMT board.

Since a test point is subject to mechanical stress, the strength of its bonding, particularly on a surface mount design, is crucial. The TP-107 achieves this through a unique forming process which doubles the surface area of the test points mounting. This is accomplished by forming the flat wire design in a spiral wrap on the mounting base resulting in an adhesion to the solder pad which requires in excess of 18 pounds of force to dislodge the test point from its solder pad.

TP-107 surface mount test points are available in two formats: bulk packaged and tape-and-reel configuration. The taped version is fully compatible with ANSI/EIA-481 standards. To insure a smooth flow to the solder pad, the TP-107 test point is plated with .0001 minimum matte tin finish over .0001 nickel underplate. The product is manufactured using Components Corporation's proprietary technology, assuring the highest possible performance.

The TP-107 is formed from phosphor bronze flat alloy wire which is spring tempered.

Recommended mounting pad dimensions are 0.185" x 0.135".

Certificate of Compliance with Directive 2002/95/EC RoHS and REACH Regulations EC 1907/2006

This is to certify that Components Corporation designs, manufactures and supplies products to our customers that are in compliance with RoHS Directive 2002/95/EC and REACH Regulations EC 1907/2006. This also pertains to procurement of raw material, component parts and processes.